

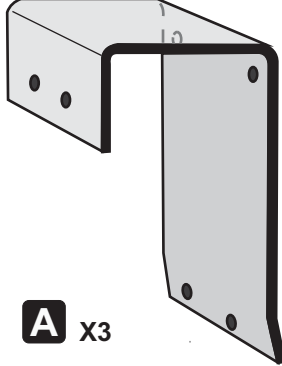

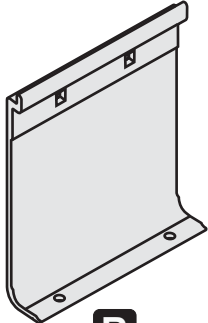

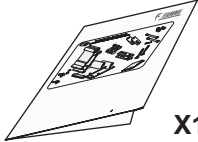
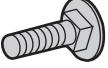

KIT FIAT DUCATO H2 ROOF RAIL

98655-625

FIAMMASTORE

(DE) VERPACKUNGSINHALT (EN) PACKAGE CONTENTS (FR) CONTENU DE L'EMBALLAGE (ES) CONTENIDO DEL EMBALAJE (IT) CONTENUTO DELL'IMBALLO		 A X3		 B X3	
 X1					
 TTLSQ M6 x 25 UNI 5732 C X12	 ø 6 UNI 6592 D X12	 M6 UNI 7473 E X12	 F X3	 4,8 x 16 UNI 6954 G X6	 M5 x 14  M5 UNI 7473 H X3

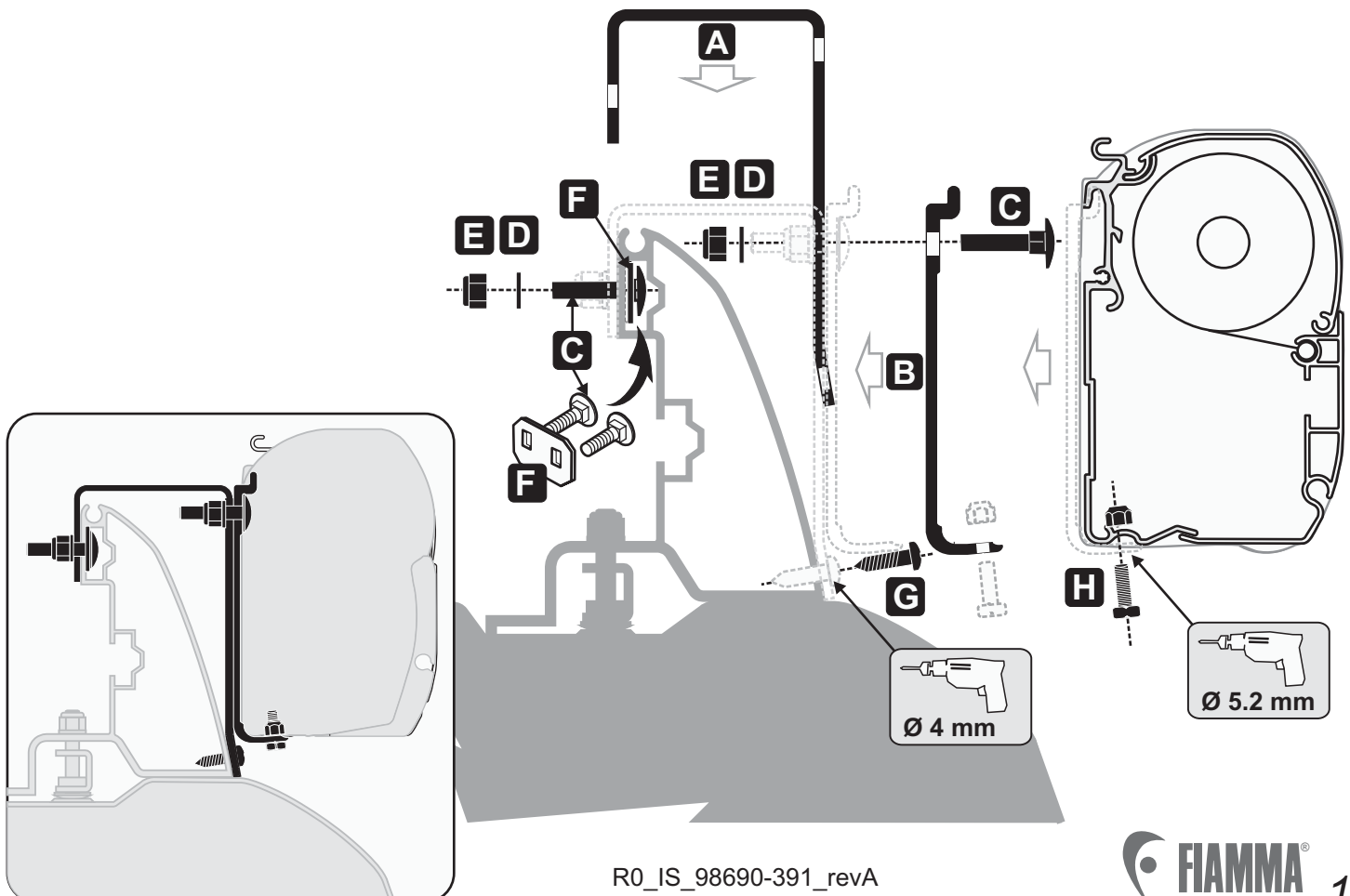

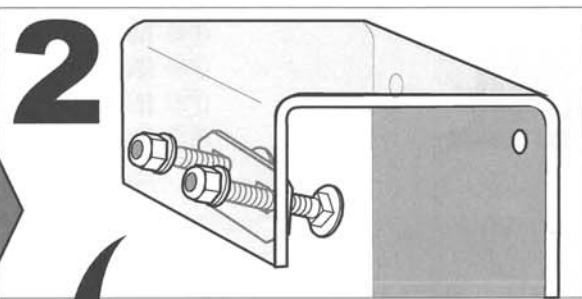
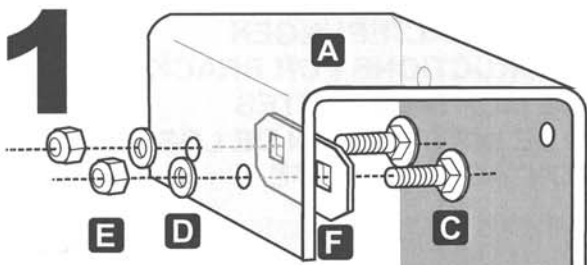

- DE Anbringung der Halterungen am Fahrzeug
- EN Installation of the brackets on the vehicle
- FR Installation des pattes sur le véhicule
- ES Instalación de los estribos sobre el vehículo
- IT Montaggio delle staffe sul mezzo

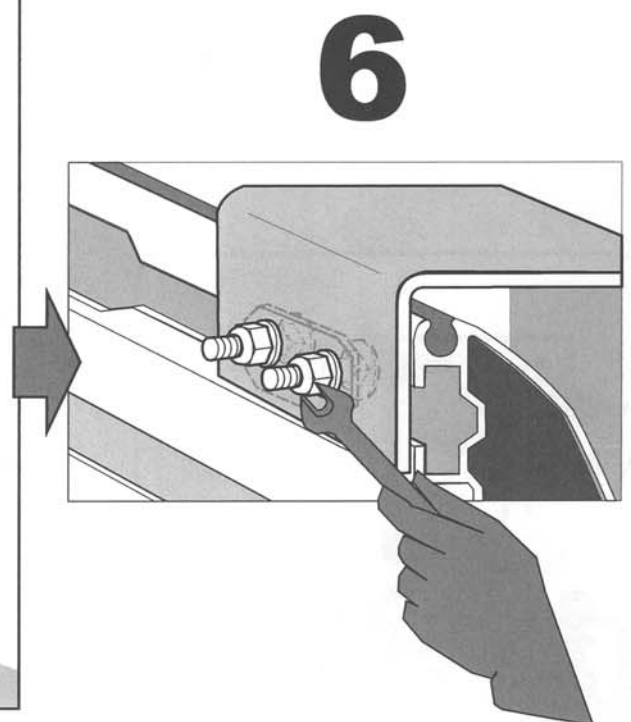
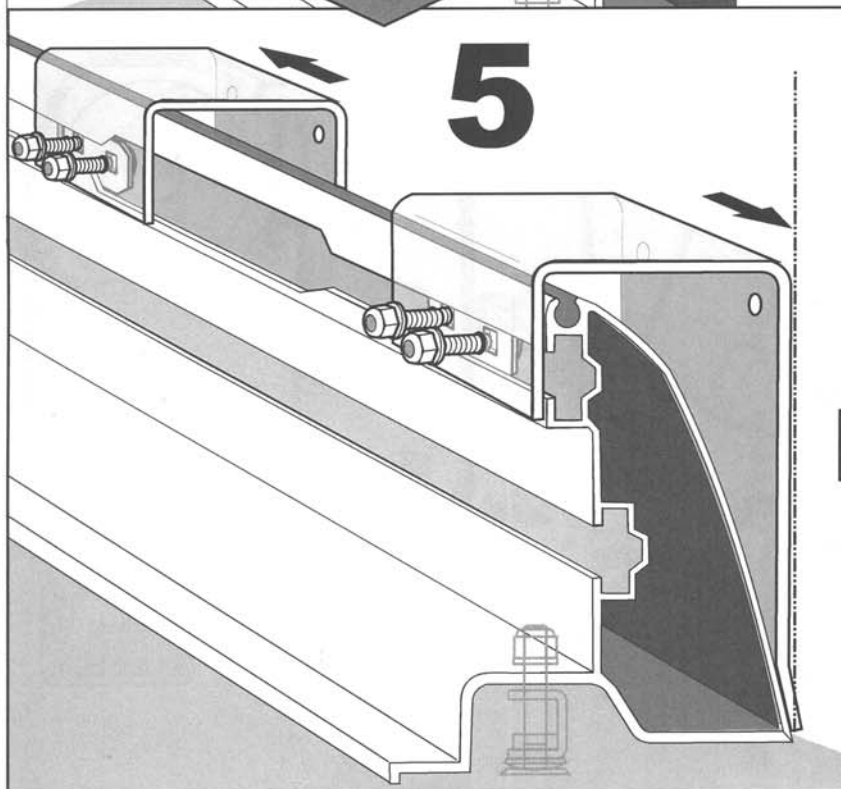
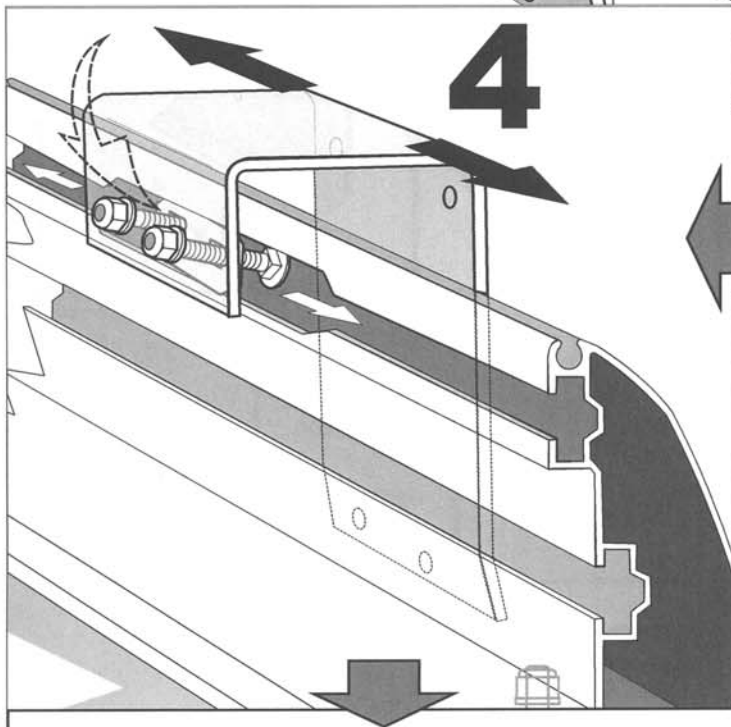
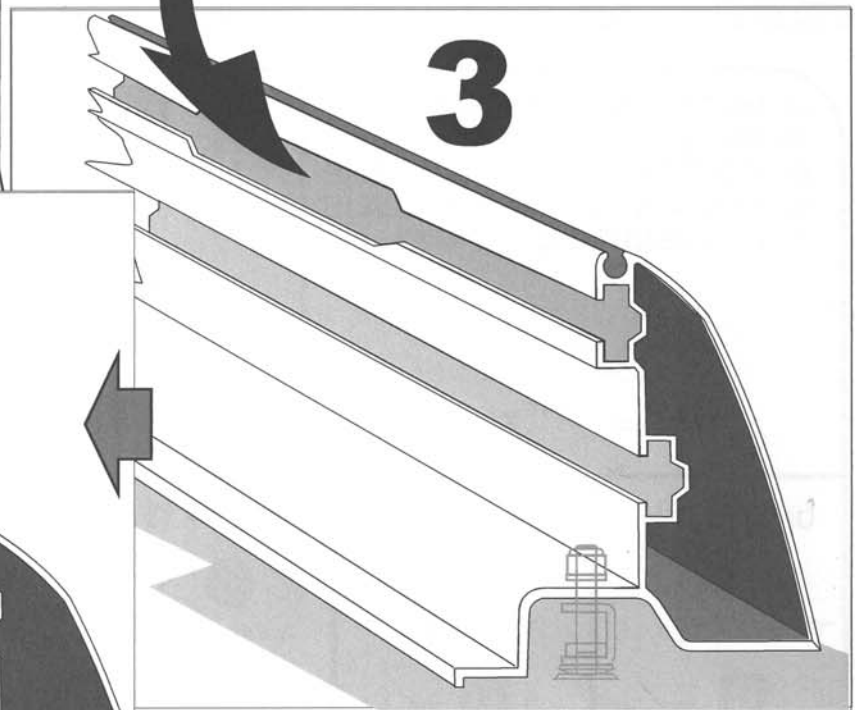

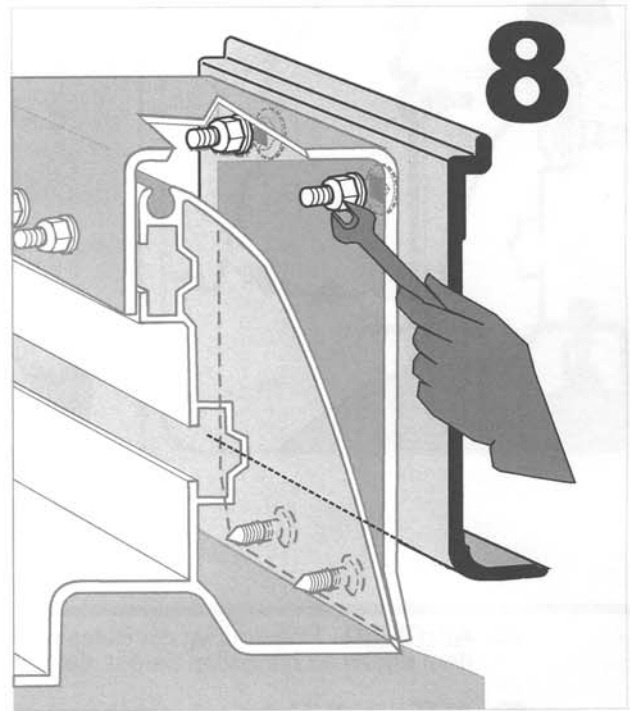
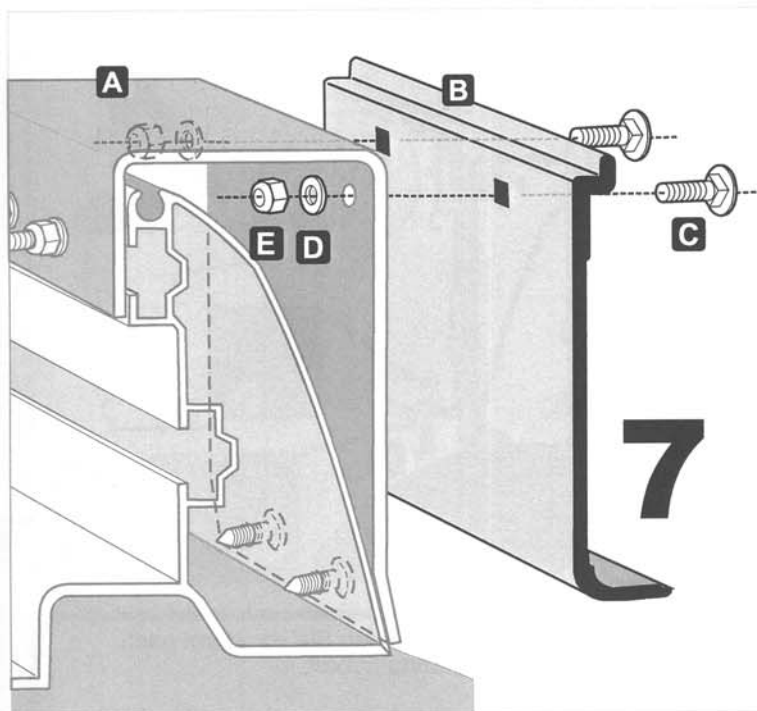
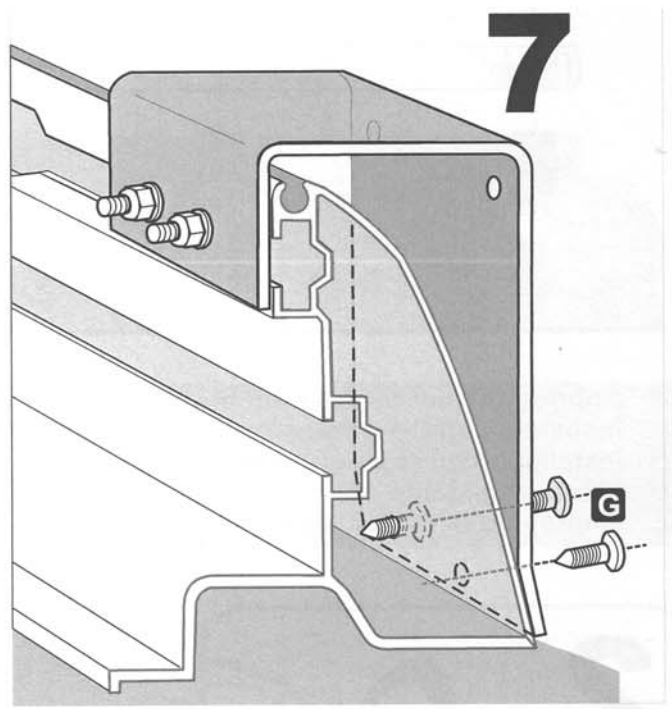
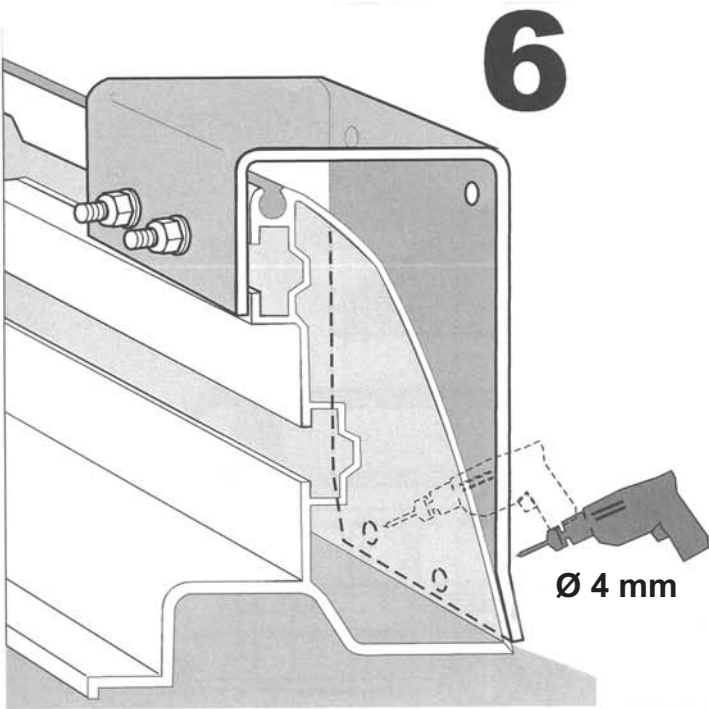

IMPORTANT WICHTIG CUIDADO IMPORTANTE

- DE** Positionieren Sie die Halterungen an den schon am Fahrzeug vorhandenen Anbringungspunkten. Versichern Sie sich, dass sich die Halterungen entsprechend der Beschriftung "SUPPORT" des Markisengehäuses und folglich entsprechend den Anbringungspunkten der Arme an dem Gehäuse befinden.
- EN** Fit the brackets on the already fixing points on the vehicle and be sure they are in correspondence of the marks "SUPPORT" of the awning and consequently of the arms fixing points on the case box.
- FR** Placer les pattes sur les points de fixation déjà prévus sur le véhicule, en s'assurant qu'elles se trouvent bien en face du symbole "SUPPORT" du store et par la suite en face du point d'attache des bras sur le boîtier.
- ES** Colocar los estribos sobre los puntos de fijación ya predispuestos sobre el vehículo, asegurándose que se encuentren a nivel de las escritas "SUPPORT" de los toldos y consiguientemente a nivel de los puntos de fijación de los brazos sobre el contenedor.
- IT** Posizionare le staffe sui punti di fissaggio già predisposti sul mezzo, assicurandosi che si trovino poi in corrispondenza delle scritte "SUPPORT" del tendalino e conseguentemente in corrispondenza al punto di fissaggio delle braccia sul cassonetto.

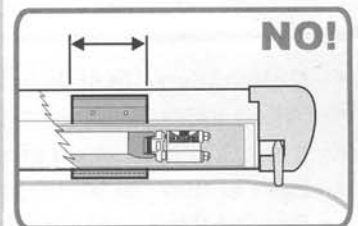
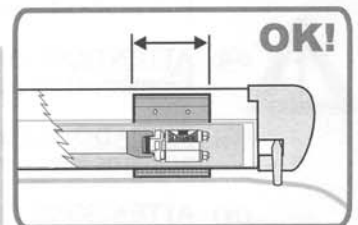

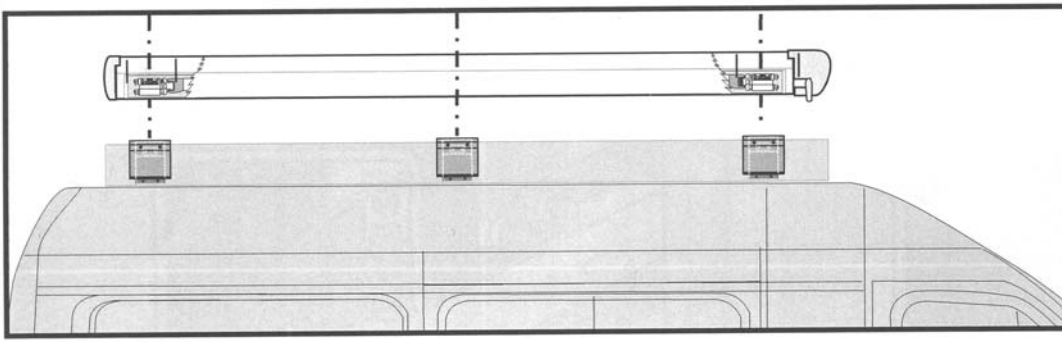

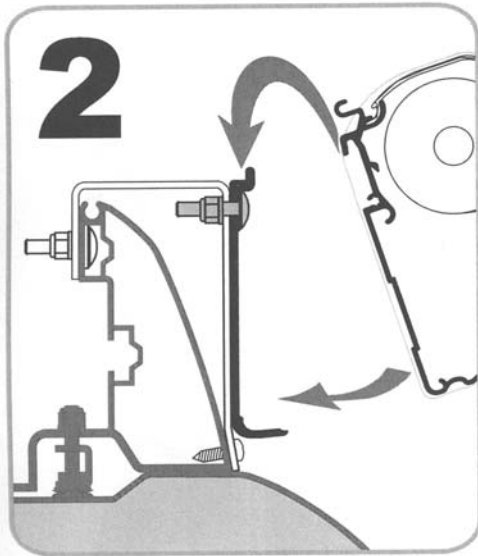
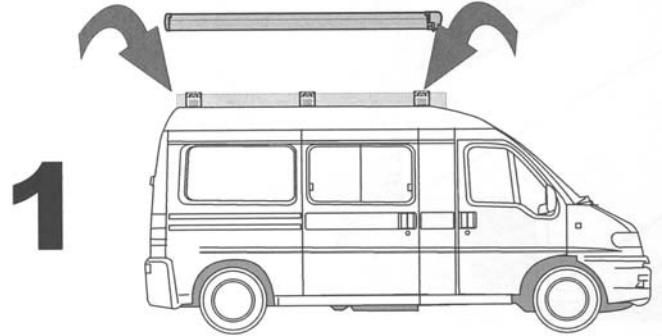

- DE Anbringung der Markise auf die Halterungen
- EN Installation of the awning on the brackets
- FR Installation du store sur les pattes
- ES Montaje del toldo sobre los estribos
- IT Montaggio del tendalino sulle staffe

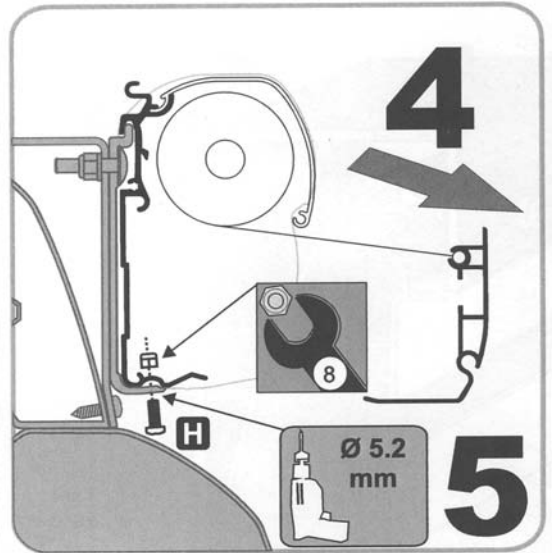

- DE Markise Ausfahren
- EN Unroll awning
- FR Ouvrir le store
- ES Abrir el toldo
- IT Aprire il tendalino



-  **DE ACHTUNG** Regelmäßig die Befestigung der Halterungen kontrollieren. Achten Sie vor allem nach dem ersten Sicherstellen darauf, dass sich die Haltebügel nicht verschoben haben.
- EN ATTENTION** Periodically check the brackets to make sure it is firmly attached (especially after the first kilometers) make sure the belts are not loose and that holding brackets have not shifted.
- FR ATTENTION** Contrôler périodiquement l'état de fixation des pattes (surtout après les premiers kilomètres) en s'assurant que les supports de fixation n'aient pas bougé.
- ES CUIDADO** Controlar periódicamente el estado de fijación de los estribos (sobre todo después de los primeros Kms) asegurándose que no se desplacen.
- IT ATTENZIONE** Controllare periodicamente lo stato di fissaggio delle staffe (soprattutto dopo i primi chilometri) assicurandosi che le stesse non si siano mosse e che i serraggi siano corretti.

- DE Bitte halten Sie sich beim Gebrauch der Markise an die Gebrauchsanweisung.
- EN When using the awning please follow the instructions of the product.
- FR Pour l'utilisation du store, se référer aux instructions du store même.
- ES Para el uso del toldo, atenerse a las instrucciones que se encuentran en el producto.
- IT Per l'utilizzo del tendalino, attenersi alle istruzioni presenti nel prodotto.

