

# ADAPTER RAPIDO 6

<b>DE</b>	Montageanleitung für die Halterungen
<b>EN</b>	Installation instructions for brackets
<b>FR</b>	Instructions de montage pattes
<b>ES</b>	Instrucciones de instalacion de los estribos
<b>IT</b>	Istruzioni di montaggio staffe

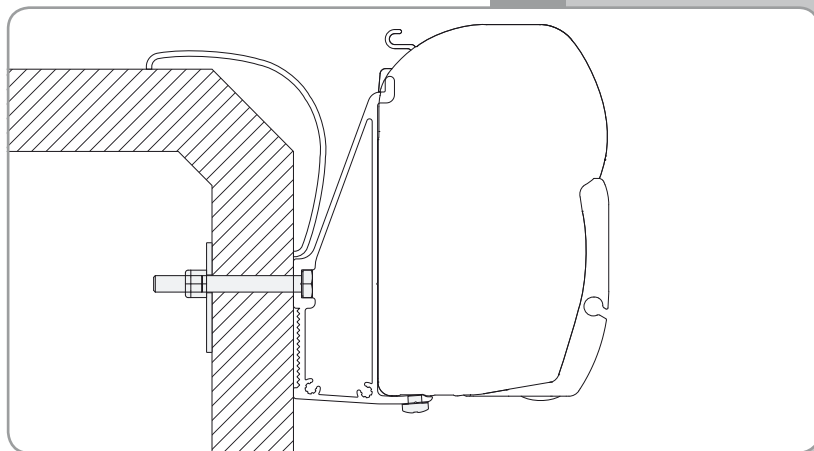

**Fiamma F45 / F70**

**DE** Produktanleitung für  
**FR** Instructions de produit pour  
**IT** Istruzioni prodotto per

**EN** Product instructions for  
**ES** Instruciones producto para

Code	Description
98655-894	Adapter Rapido 6 - 300
98655-895	Adapter Rapido 6 - 350
98655-896	Adapter Rapido 6 - 400

**DE** Verpackungsinhalt  
**FR** Contenu de l'emballage  
**IT** Contenuto dell'imballo

**EN** Package contents  
**ES** Contenido del embalaje

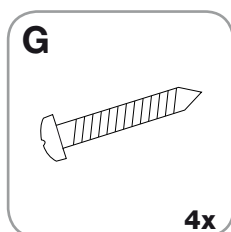
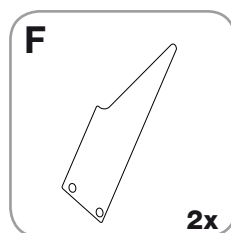
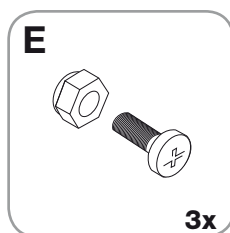
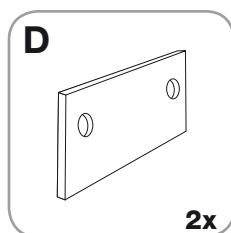
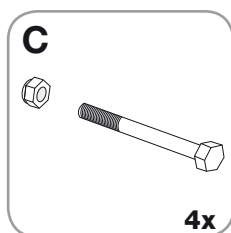
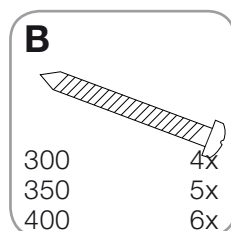
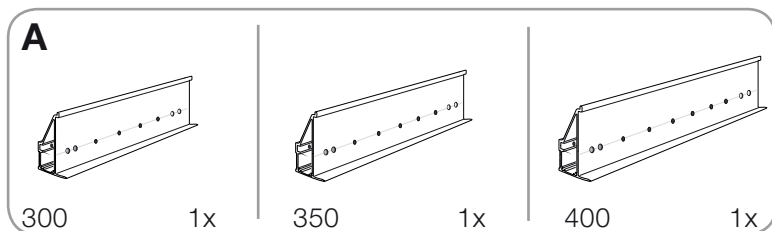
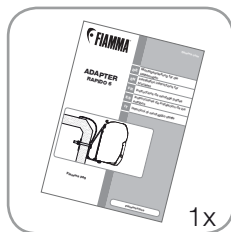

- DE** Anbringung der Halterungen am Fahrzeug  
**EN** Installation of the brackets on the vehicle  
**FR** Installation des pattes sur le véhicule  
**ES** Instalación de los estribos sobre el vehículo  
**IT** Montaggio delle staffe sul mezzo

**1**

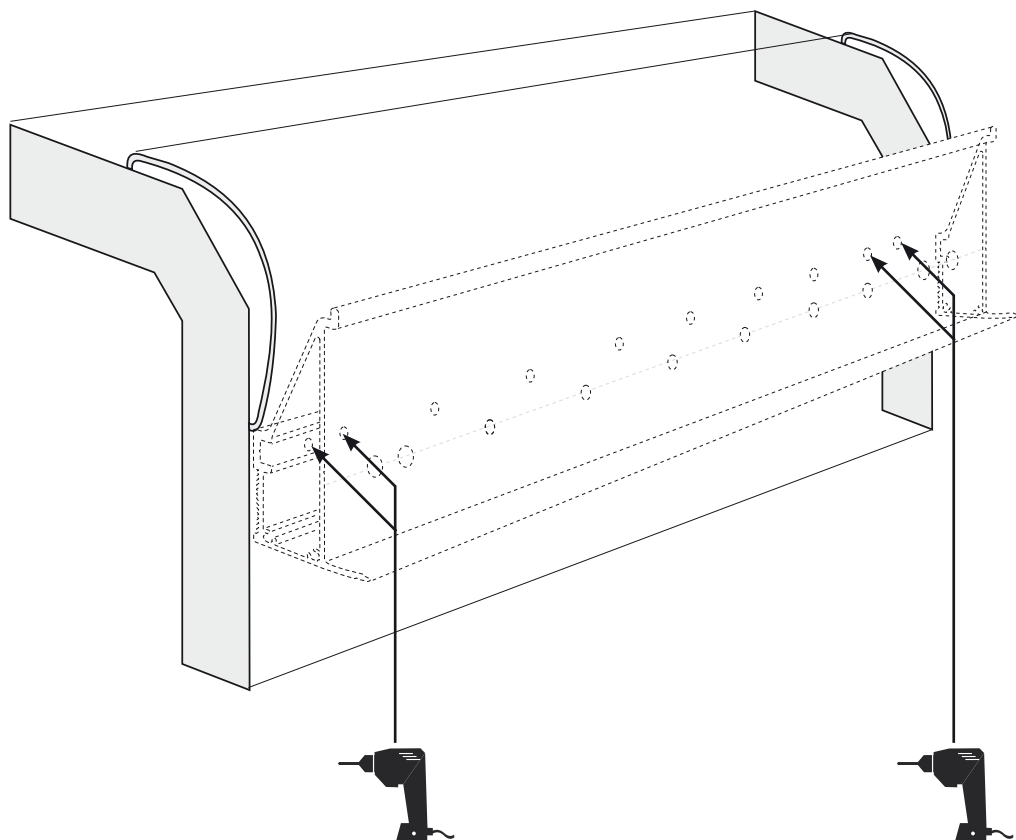

**2**

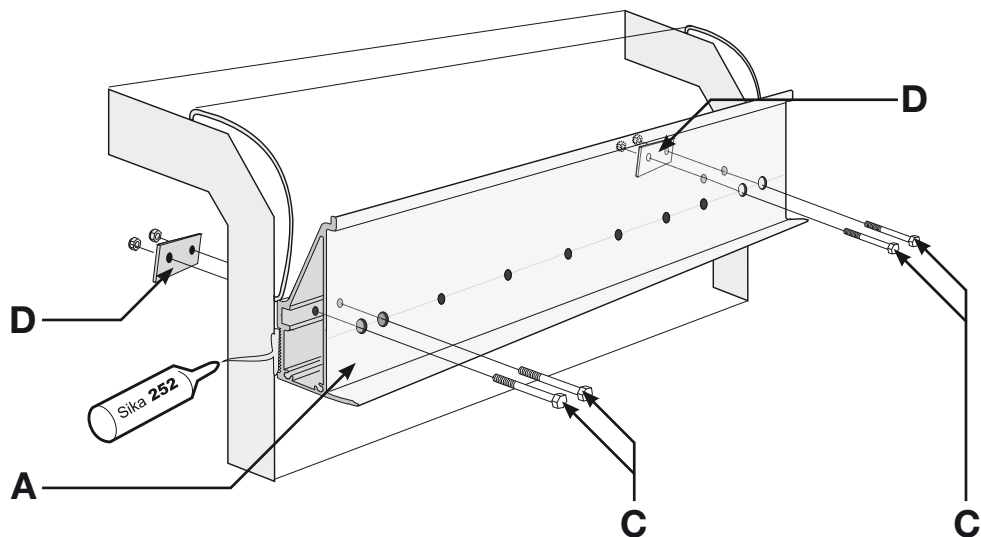

**3**

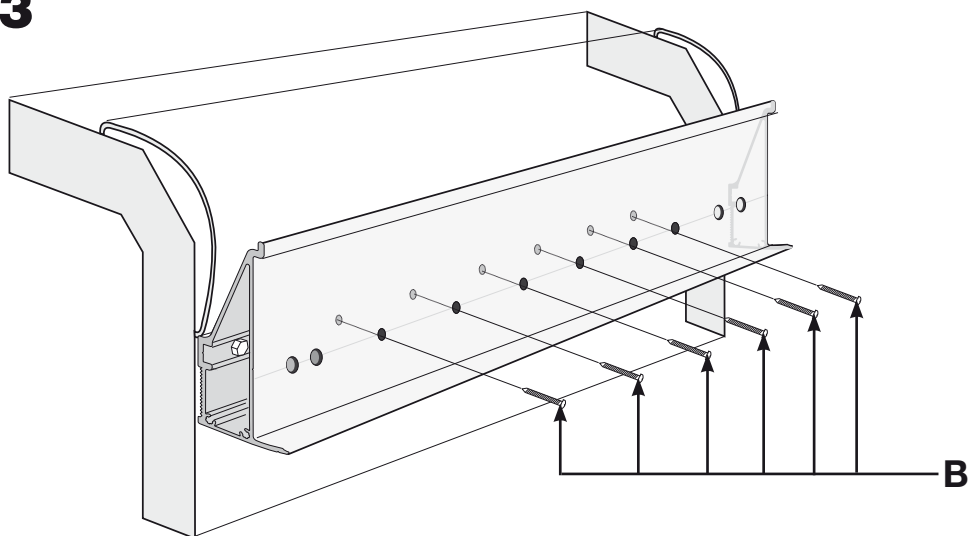

**4**

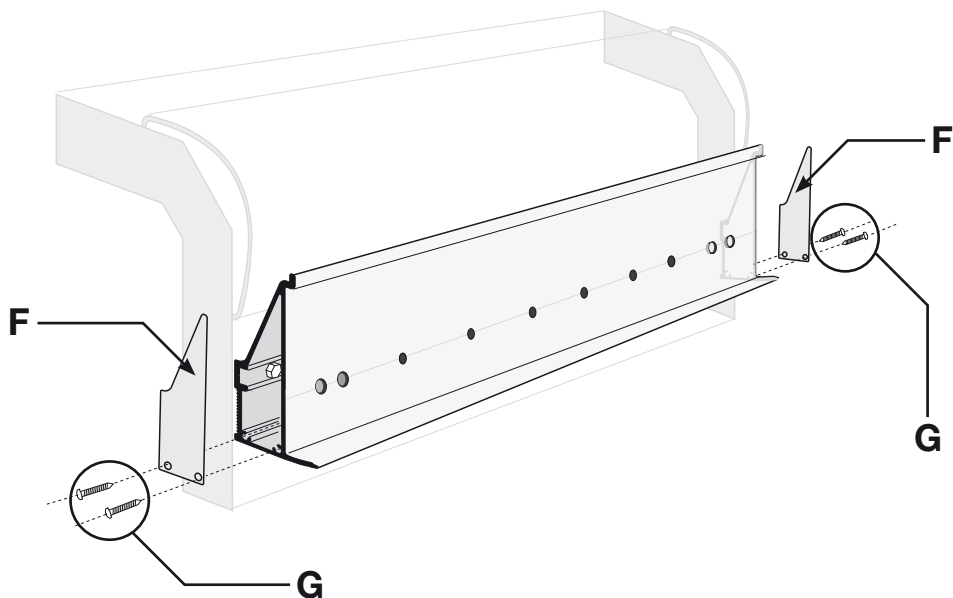

- DE** Anbringung der Markise auf die Halterungen  
**EN** Installation of the awning on the brackets  
**FR** Installation du store sur les pattes  
**ES** Fijación del toldo sobre los estribos  
**IT** Montaggio del tendalino sulle staffe

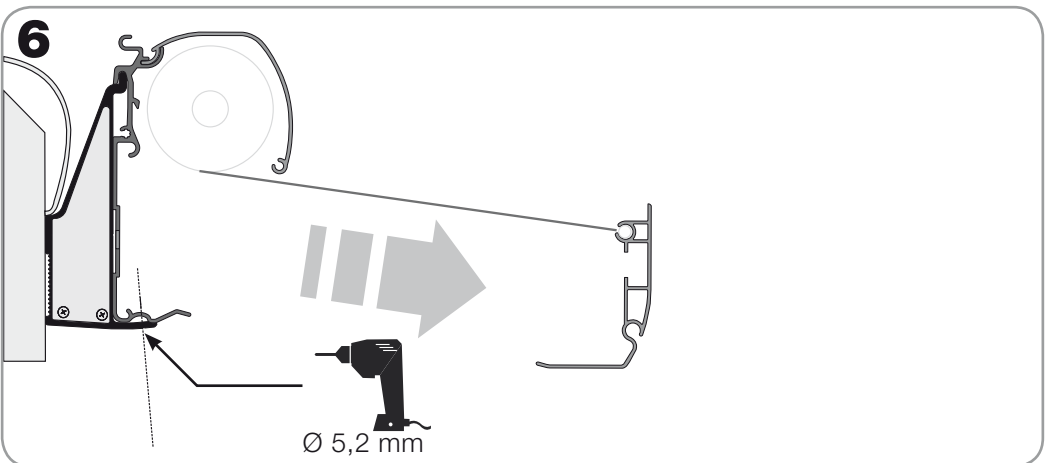
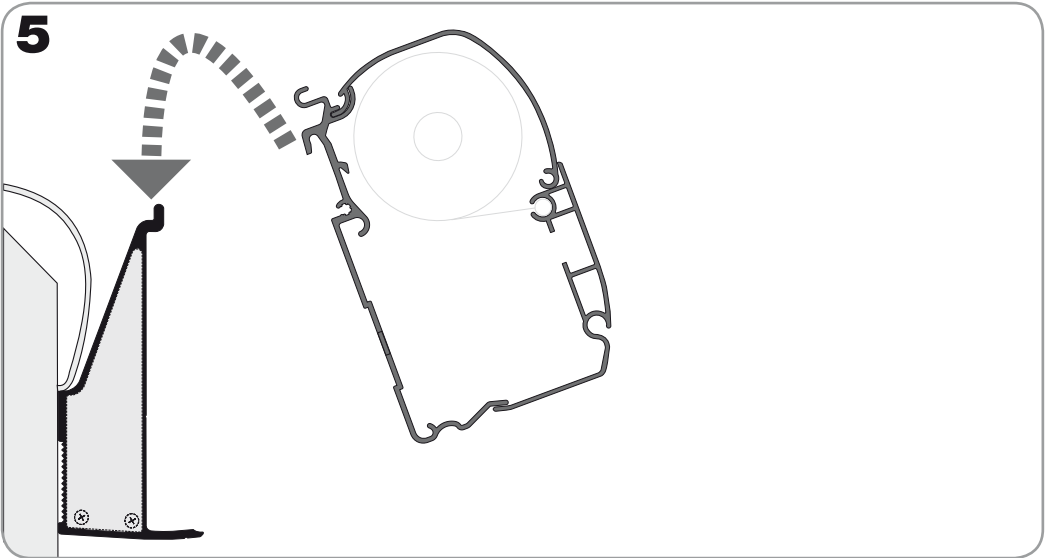

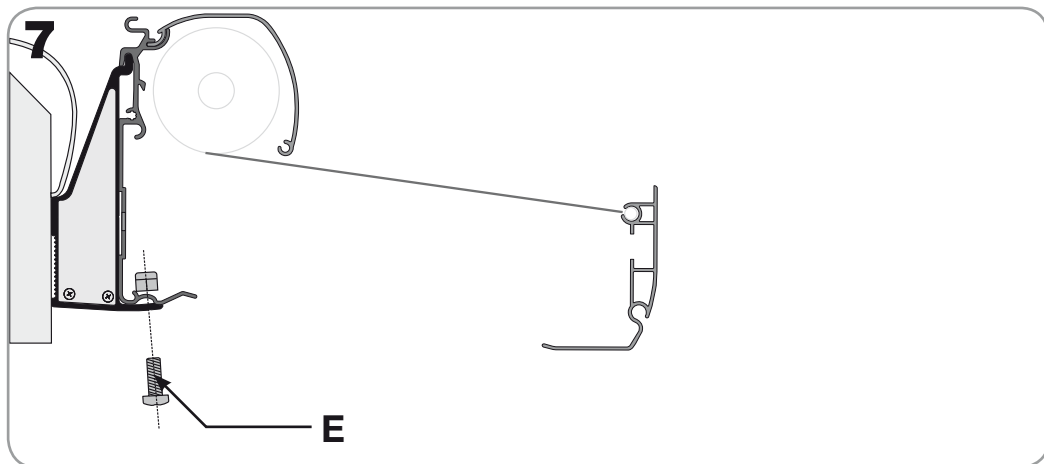



**DE** **ACHTUNG** Regelmäßig die Befestigung für die Halterungen kontrollieren. Achten Sie vor allem nach den ersten Kilometern darauf, dass sich die Haltebügel nicht verschoben haben

**EN** **ATTENTION** Periodically check the brackets to make sure they are firmly attached (especially after the first kilometers), make sure that the bolts are not loose and that holding brackets have not shifted

**FR** **ATTENTION** Contrôler périodiquement l'état de fixation des pattes (surtout après les premiers kilomètres) en s'assurant que les supports de fixation n'aient pas bougé

**ES** **CUIDADO** Controlar periódicamente el estado de fijación de los estribos (sobre todo después de los primeros Kms) asegurándose que no se desplacen

**IT** **ATTENZIONE** Controllare periodicamente lo stato di fissaggio delle staffe (soprattutto dopo i primi chilometri) assicurandosi che le stesse non si siano mosse e che i serraggi siano corretti

**DE** Bitte halten Sie sich beim Gebrauch für die Markise an die Gebrauchsanweisung

**EN** When using the awning please follow the instructions of the product

**FR** Pour l'utilisation du store, se référer aux instructions du store même.

**ES** Para el uso del toldo, atenerse a las instrucciones que se encuentran en el producto

**IT** Per l'utilizzo del tendalino, attenersi alle istruzioni presenti nel prodotto

**DE** Im Falle einer Vertragswidrigkeit der Ware, kann der Verbraucher unter den erforderlichen Voraussetzungen gegenüber dem Verkäufer von dem Garantieanspruch zu den festgelegten Bedingungen gemäss den lokalen Rechtsvorschriften Gebrauch machen.

**EN** In case of defects with regards to materials and manufacturing, the customer is entitled to the warranty in accordance with local laws and regulations of the country in which the product was purchased.

**FR** En cas d'un défaut de conformité du produit, le consommateur pourra faire valoir ses droits de recours en garantie selon les modalités prévues par les dispositions légales locales, pour autant que les conditions de recours soient remplies.

**ES** En caso de fallos o defectos de material y de fabricación, el cliente puede hacer valer la garantía de acuerdo con las leyes y reglamentaciones del país en el que el producto haya sido comprado.

**IT** In caso di difetto di conformità dei beni, il consumatore potrà far valere nei confronti del venditore la garanzia secondo le modalità previste dalle disposizioni di legge locali, ove ne ricorrano i presupposti.





fiamma.com

All rights reserved.

Fiamma S.p.A. reserves the right to modify at any time, without notice, prices, materials, specifications and models or to cease production of any model.

**Fiamma SpA - Italy**  
Via San Rocco, 56  
21010 Cardano al Campo (VA)

98655-894 Adapter Rapido 6 300  
98655-895 Adapter Rapido 6 350  
98655-896 Adapter Rapido 6 400

R0\_IS\_98690-830\_revB

**Fiammastore**