

ADAPTER RAPIDO 90df-9M-10

DE	Montageanleitung für die Halterungen
EN	Installation instructions for brackets
FR	Instructions de montage pattes
ES	Instrucciones de instalacion de los estribos
IT	Istruzioni di montaggio staffe

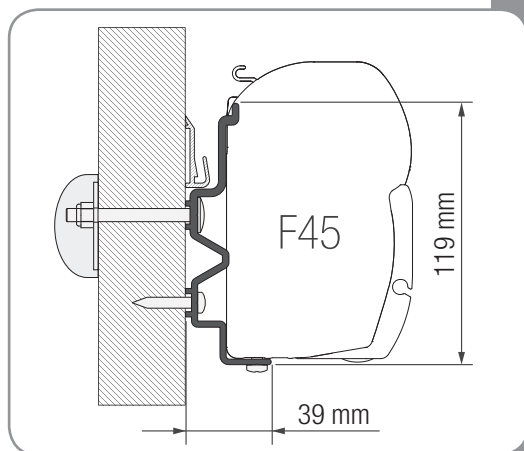

DE **ACHTUNG** Regelmässig die Befestigung der Halterungen kontrollieren. Achten Sie vor allem nach den ersten Kilometern darauf, dass sich die Haltebügel nicht verschoben haben.

EN **ATTENTION** Periodically check the brackets to make sure they are firmly attached (especially after the first miles), make sure the belts are not loose and that holding brackets have not shifted.

FR **ATTENTION** Contrôler périodiquement l'état de fixation des pattes (surtout après les premiers kilomètres), en s'assurant que les supports de fixation n'aient pas bougé.

ES **CUIDADO** Controlar periódicamente el estado de fijación de los estribos (sobre todo después de los primeros Kms), asegurándose que no se desplacen.

IT **ATTENZIONE** Controllare periodicamente lo stato di fissaggio delle staffe (soprattutto dopo i primi chilometri), assicurandosi che le stesse non si siano mosse e che i serraggi siano corretti.

DE Bitte halten Sie sich beim Gebrauch für die Markise an die Gebrauchsanweisung.

EN When using the awning please follow the instructions of the product.

FR Pour l'utilisation du store, se référer aux instructions du store même.

ES Para el uso del toldo, atenerse a las instrucciones que se encuentran en el producto.

IT Per l'utilizzo del tendalino, attenersi alle istruzioni presenti nel prodotto.

DE Verpackungsinhalt
FR Contenu de l'emballage
IT Contenuto dell'imballo

EN Package contents
ES Contenido del embalaje

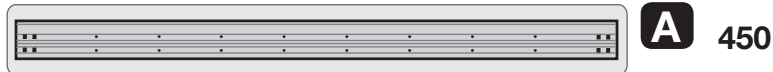
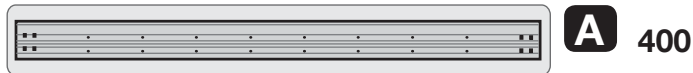

B x8



C x8



D x4



E x8



F x16



G x3



x1

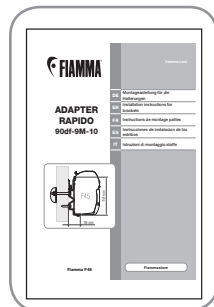

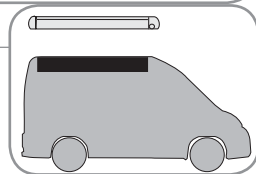

DE

ACHTUNG: ANBRINGUNG AUF LANGEN ADAPTER

Vergewissern Sie sich, dass der Adapter geradlinig montiert ist. Ebenso sollte kontrolliert werden, ob Unebenheiten am Fahrzeug vorhanden sind; in diesem Falle mit Distanzstücken ausgleichen, um so die gleiche Positionierung zu garantieren. Die Anbringung der Markise kann nur durch geradlinig anliegenden Adapter an der Fahrzeugwand erfolgen.

EN

ATTENTION: INSTALLATION ON ADAPTER

Ensure that the adapter is mounted linearly and not present curves or deformation due to the vehicle: in these cases, shim appropriately to ensure the linearity of the bracket. The installation of the awning can occur only when the adapter is perfectly aligned to the wall of the vehicle.

FR

ATTENTION: INSTALLATION SUR ADAPTATEUR

Vérifier que l'adaptateur soit monté de manière linéaire et ne présente pas de courbure ou de déformations à cause du véhicule. Dans ces cas-là, donner l'épaisseur nécessaire pour garantir le bon alignement de l'étrier. L'installation du store pourra se faire seulement une fois que l'adaptateur sera parfaitement aligné contre la paroi du véhicule.

ES

IMPORTANTE: INSTALACIÓN EN ADAPTADOR

Asegurarse de que el adaptador está montado curvas linealmente y que no están presentes curvas o deformaciones debidas al vehículo: en estos casos, suplementar apropiadamente para asegurar la linealidad del soporte. La instalación del toldo sólo puede ocurrir con el adaptador perfectamente alineado a la pared del vehículo.

IT

IMPORTANTE: INSTALLAZIONE SU ADAPTER

Assicurarsi che l'adapter sia montato linearmente e non presenti curve o deformazioni dovute al mezzo: in questi casi, spessorare opportunamente per garantire la linearità della staffa. L'installazione del tendalino può avvenire solo ad adapter perfettamente allineato alla parete del veicolo.

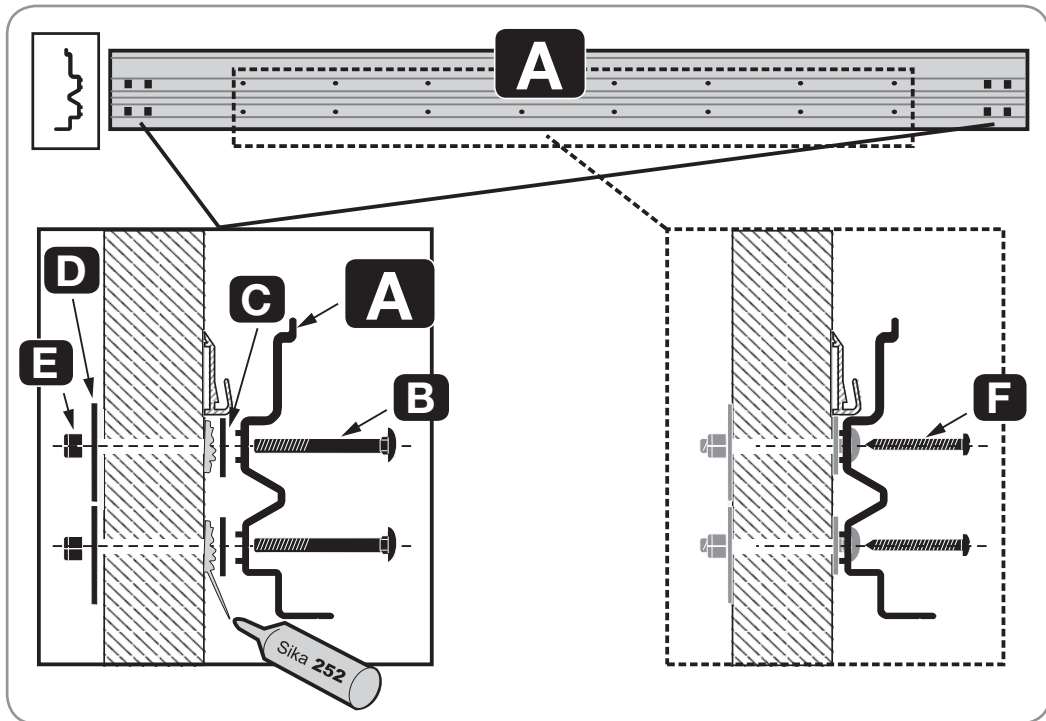

- DE Anbringung der Halterungen am Fahrzeug
 EN Installation of the brackets on the vehicle
 FR Installation des pattes sur le véhicule
 ES Instalación de los estribos sobre el vehículo
 IT Montaggio delle staffe sul mezzo

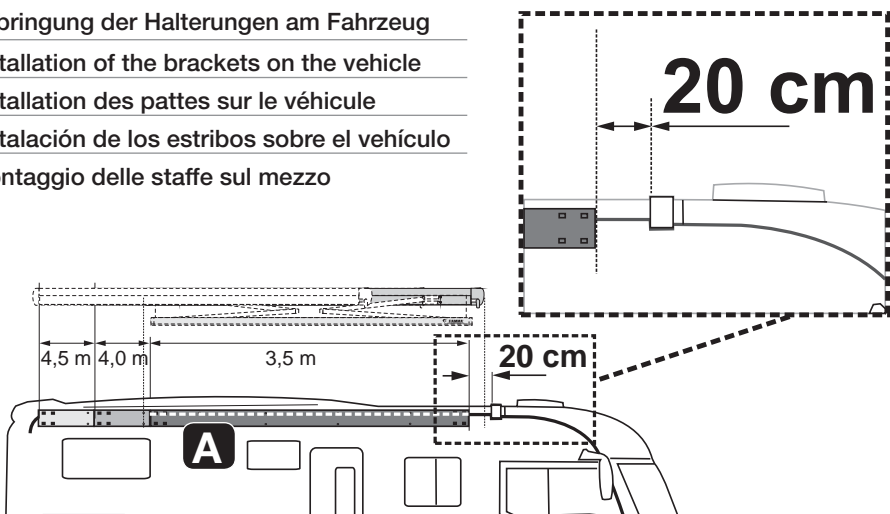

DE Anbringung der Halterungen am Fahrzeug

EN Installation of the brackets on the vehicle

FR Installation des pattes sur le véhicule

ES Instalación de los estribos sobre el vehículo

IT Montaggio delle staffe sul mezzo

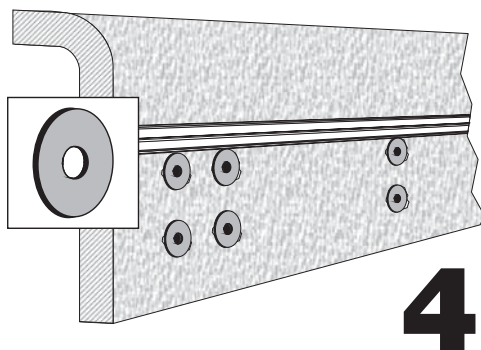
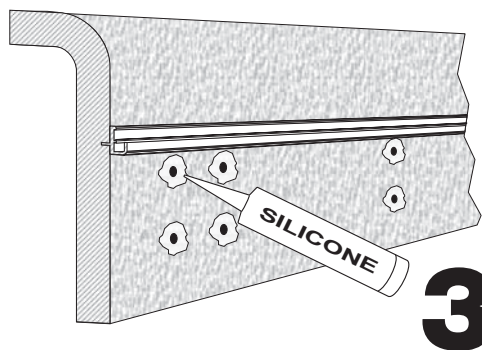
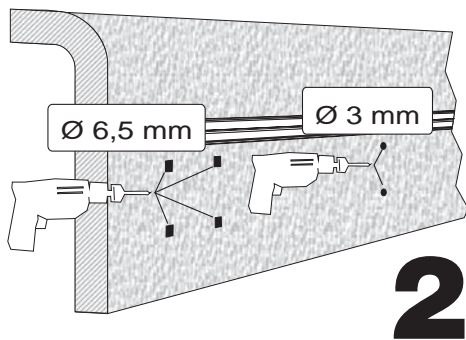
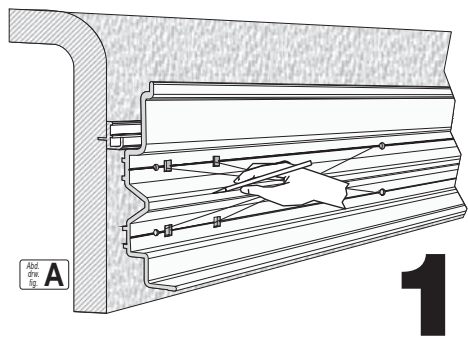
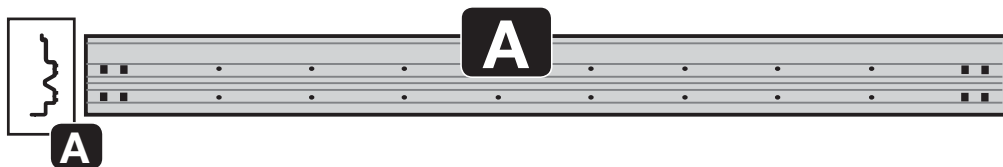

5

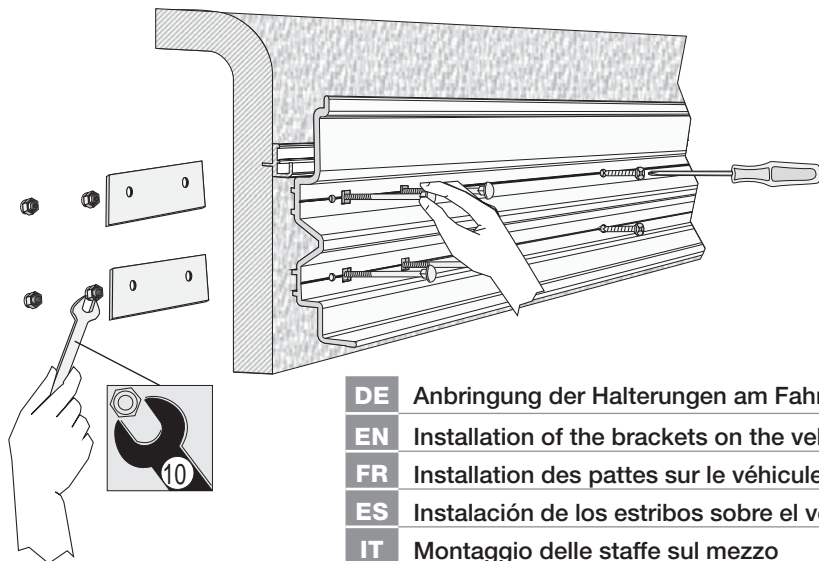

6

- DE** Anbringung der Markise auf die Halterungen
EN Installation of the awning on the brackets
FR Installation du store sur les pattes
ES Fijación del toldo sobre los estribos
IT Montaggio del tendalino sulle staffe

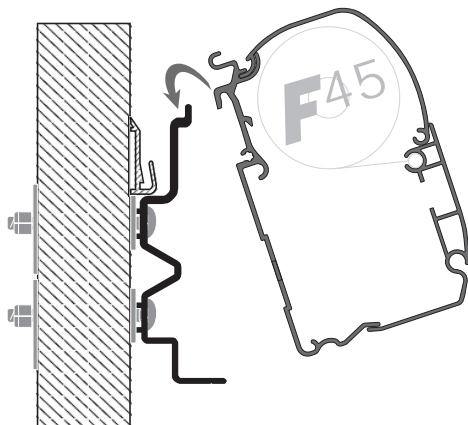
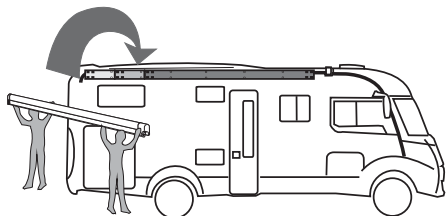

DE Anbringung der Markise auf die Halterungen

EN Installation of the awning on the brackets

FR Installation du store sur les pattes

ES Fijación del toldo sobre los estribos

IT Montaggio del tendalino sulle staffe

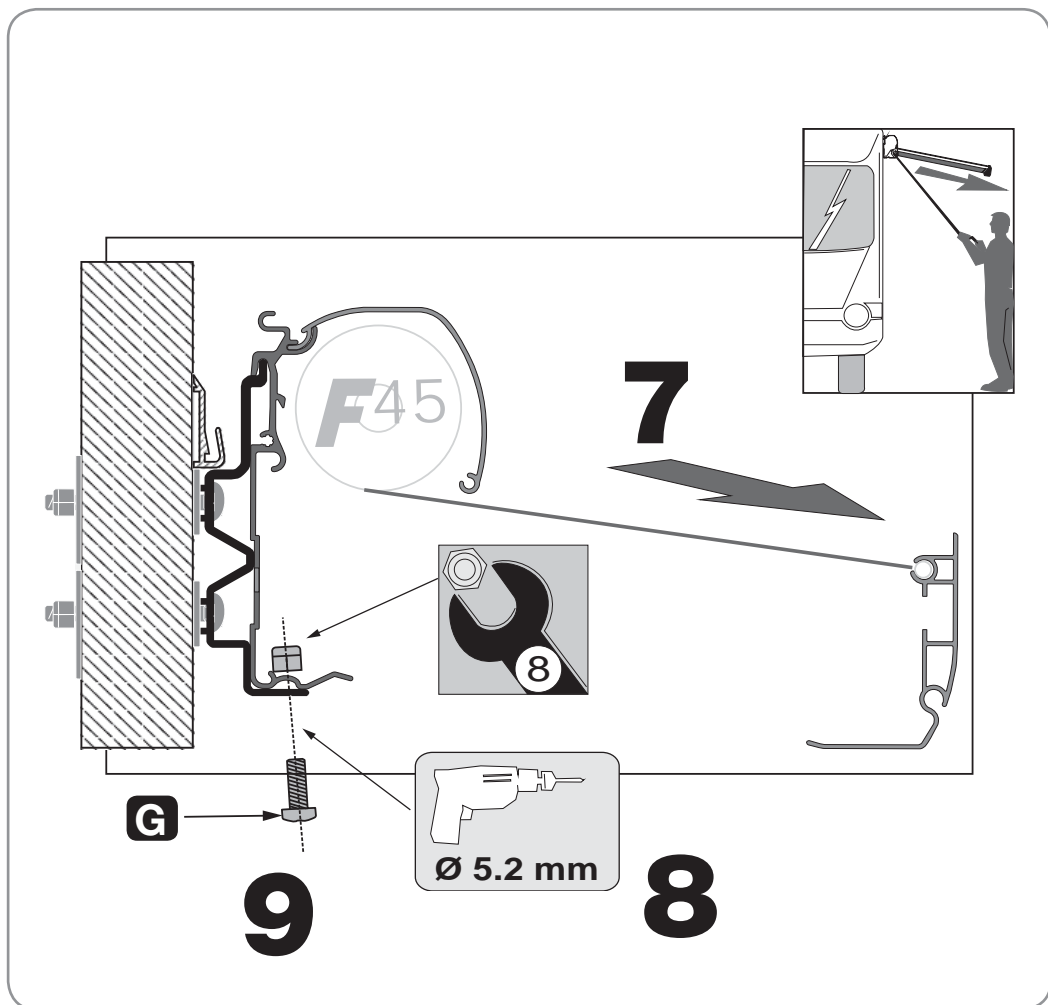

DE Im Falle einer Vertragswidrigkeit der Ware, kann der Verbraucher unter den erforderlichen Voraussetzungen gegenüber dem Verkäufer von dem Garantieanspruch zu den festgelegten Bedingungen gemäss den lokalen Rechtsvorschriften Gebrauch machen.

EN In case of defects with regards to materials and manufacturing, the customer is entitled to the warranty in accordance with local laws and regulations of the country in which the product was purchased.

FR En cas d'un défaut de conformité du produit, le consommateur pourra faire valoir ses droits de recours en garantie selon les modalités prévues par les dispositions légales locales, pour autant que les conditions de recours soient remplies.

ES En caso de fallos o defectos de material y de fabricación, el cliente puede hacer valer la garantía de acuerdo con las leyes y reglamentaciones del país en el que el producto haya sido comprado.

IT In caso di difetto di conformità dei beni, il consumatore potrà far valere nei confronti del venditore la garanzia secondo le modalità previste dalle disposizioni di legge locali, ove ne ricorrano i presupposti.



fiamma.com

All rights reserved.

Fiamma S.p.A. reserves the right to modify at any time, without notice, prices, materials, specifications and models or to cease production of any model.

Fiamma SpA - Italy
Via San Rocco, 56
21010 Cardano al Campo (VA)

350 98655-916
400 98655-917
450 98655-918

RO_IS_98690-907_revD

Fiammastore